

1 PC BALL VALVE

Type 111A

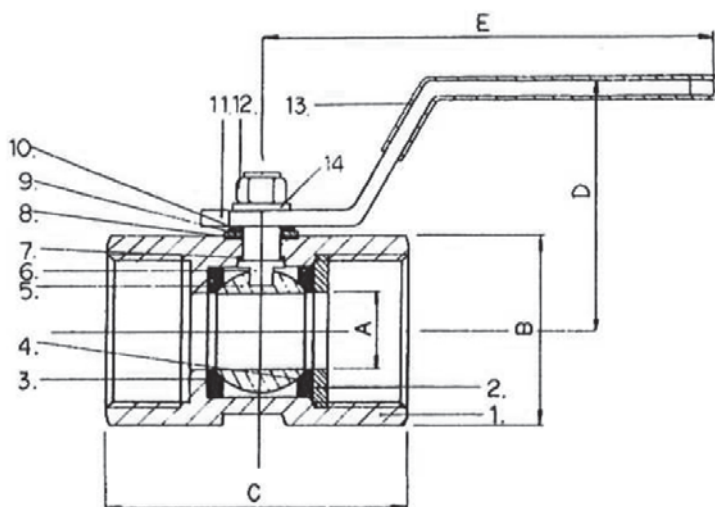

Stainless Steel reduced bore, 1000 WOG screwed ends



FEATURES

- » Pressure rating 1000 psi non-shock for water, oil and gas
- » Temperature range 0°C to 204.4°C (0°F - 400°F)
- » Glass reinforced P.T.F.E. seals and seats
- » Stainless steel handle, plastic insulated
- » 100% factory tested air underwater in open and closed position
- » Female/female thread - BSP.T, BSP.P, NPT
- » Can be applied in Chemical and Petrochemical Industries, Food Industries, Pharmaceutical Industries, Steam Power Plant.

No	Part Name	Material
1	Body	S/S316
2	Seat Retainer	S/S316
3	Seat	PTFE + 15% G.F
4	Special Seat	PTFE + 15% G.F
5	Ball	S/S316
6	Stem	S/S316
7	Gasket	PTFE + 15% G.F
8	Thin Gasket	PTFE + 15% G.F
9	Flat Washer	420J1
10	Belleville Spring Washer	420J1
11	Handle	S/S304
12	Locking Nut	S/S304
13	Plastic Coating	PVC
14	Level Spring Washer	S/S304

Size		A	B	C	D	E
mm	inch	mm	mm	mm	mm	mm
8	1/4	4.6	17.1	38.7	27.2	58.0
10	3/8	7.0	20.7	44.2	29.0	78.0
15	1/2	9.0	24.8	55.6	36.5	85.0
20	3/4	12.5	31.4	62.1	39.8	85.0
25	1	16.0	38.2	68.9	49.1	100.0
32	1 1/4	20.0	47.0	78.2	53.5	100.0
40	1 1/2	24.5	53.0	86.0	61.5	125.0
50	2	32.0	65.2	102.7	67.6	125.0

*last updated 10/18